

THE SmartPick™ MAGNET CONTROL SYSTEM

SAFETY

The safety concept of the SmartPick™ (SP™) embraces many functions that are performed seamlessly in the background of magnet operations.

Magnets controlled by SP™ always grip their loads initially with reduced lifting power. As soon as the load is lifted, the SP™ switches over automatically to full load, adding additional safety factor. Every time the magnets are energised, the backup battery function is tested and, if it is faulty, the energising process is stopped.

The battery backup feature provides an independent power supply, which safeguards in the event of a power failure or a defect in the control system. Any failure of the power supply is detected immediately, even if only one phase is affected.

Protection from “Short” or “Open Circuit” conditions is available for the latest, twin-coil magnets, in conjunction with dual PowerPick and dual cable feeds to the magnet. Each of the twin coils in the magnet head can retain the full rated load of the magnet, so if one of the two magnet cables is damaged/faulty, the magnet will still retain the load with the 2nd un-affected coil in operation. The cable paths are constantly monitored by SP™.

The temperatures of the magnets are also measured and monitored continuously to prevent any overheating of the magnets. Standard system interlocks prevent crane movements unless in full power, as well as preventing accidental power-off of the magnet (load cell on crane required).

The safety level of the SP™ - Category 4 for the controller - exceeds all existing national standards, as well as CEN standards for load lifting equipment.

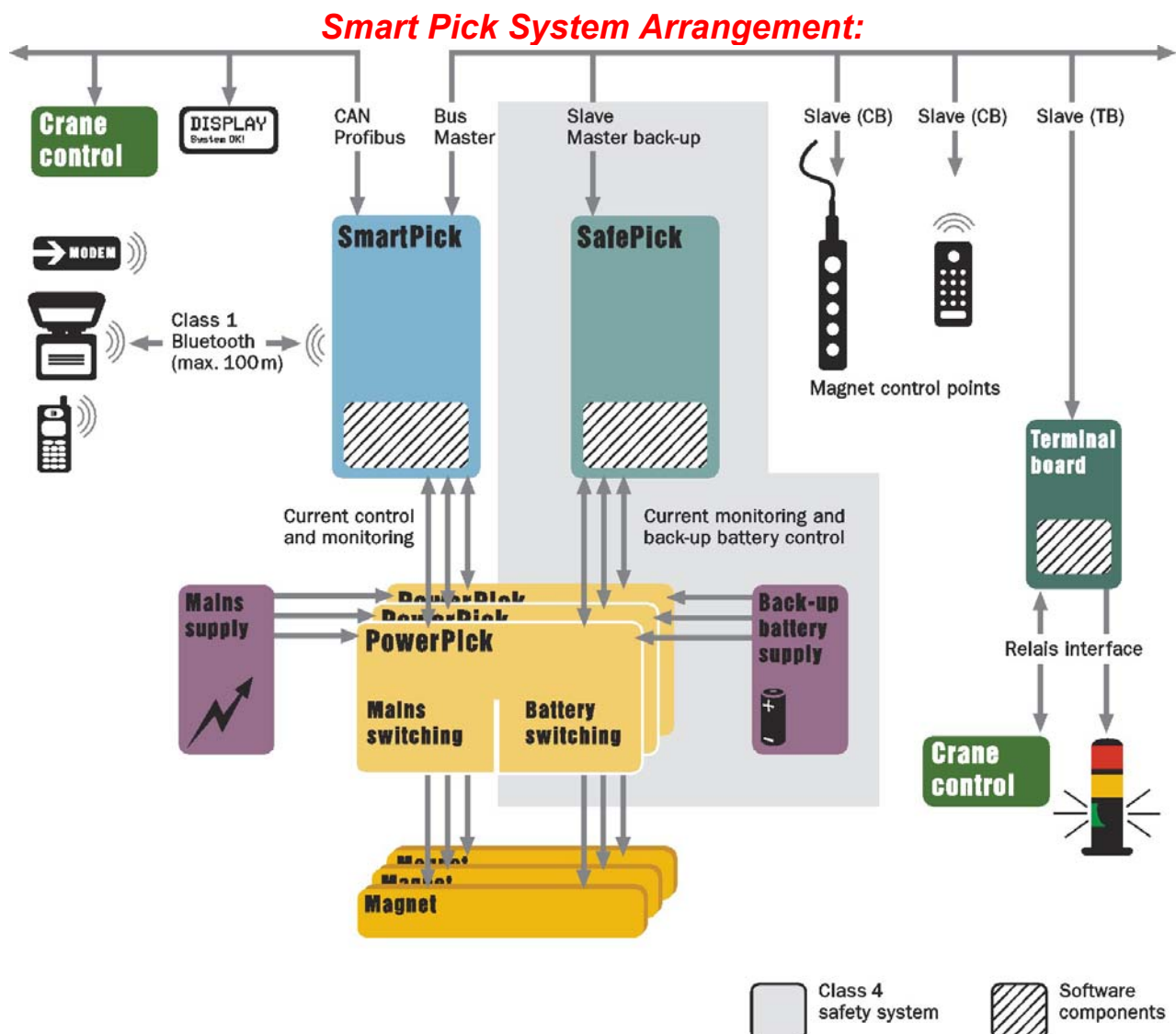

SUMMARY OF SmartPick™ FEATURES

TRUNINGER's SmartPick™ control system is comprised of three (3) main modules:-

i. The SmartPick™ module:

- Easy integration into any crane system
- Worldwide compatibility (CAN, Profibus or relay interfaces)
- Bluetooth™ radio interface for remote access to information
- Unhindered condition monitoring during magnet operation by means of a laptop at ground level
- Remote controlled maintenance via cell phone or radio modem for fast and competent error recovery
- Blackbox recorder for the precise reconstruction of system errors
- Full text display for system monitoring and fault diagnostics.
- Initial lifting at 60% of full power to ensure the highest levels of safety
- Automatic switching to 100% power after the initial 60% lift

ii. The PowerPick™ module:

- Fastest magnetising and demagnetising on the world market
- Powerful magnetising up to 2.4 Tesla (saturation of steel)
- Most exact current resolution to demagnetise below 0.001 Tesla (10 Gauss). Metal chips no longer adhere to the loads being handled
- Over excitation system to provide higher levels of magnet power when picking product
- Either completely independent or synchronised operation of up to 8 magnet groups
- Sealed housing with the latest cooling technology that high-performance electronics can provide
- Fault-free operation in dusty, damp or hot conditions
- Monitoring of the magnet coil temperatures and automatic shut-down if temperatures become critical
- Connection of redundant feeds to the magnets with integrated monitoring of both paths.
- Non-contactor control to provide the utmost in reliability

iii. The SafePick™ module:

- The first parallel computer module for magnet control systems in the world
- **Safety Class 4 (as per EN 954-1)**
- Detects malfunctions and automatically assumes control of the magnet installation from the master, SmartPick™ module
- Constantly checks the function of the SmartPick™ module
- Ceaselessly checks the function of the "Emergency ON" circuit (battery back-up system)
- Monitors magnet current without interruption
- Switches from mains to battery back-up operation automatically if a break in the power supply is detected
- Automatic, seamless return to mains power on restoration of line power
- Monitors, maintains and charges the battery back-up independently
- Ensures full function of all indicators and control system when in battery mode.

SmartPick Systems also feature, as standard:

- Safety interlocks to & from the crane/machinery controls - travel lock till Partial load reached, accidental MAG OFF over-ride, etc
- Comprehensive magnet status indication systems for operator and ground level personnel
- Full visual and aural warning systems to warn of any detected system errors
- Easily up-gradable to cope with future changes to handling characteristics.

QUALITY

Stringent manufacturing standards, applied by qualified personnel and utilizing high-grade components, ensure optimum levels of quality.

SP™ also guarantees the quality of the material handled. While the magnets are de-energised, the “Downcycle Degauss System” of de-magnetisation eliminates any residual magnetism, enabling the handling of “special” steels which are susceptible to down-stream issues with residual magnetism. With this option, chips adhering to the material are a thing of the past.

SmartPick™ Controller for 2 Magnet Groups



TIME

In terms of handling time, SP™ fully lives up to its name. Impulse excitation of the magnets means that the time needed to build up and clear the magnetic field is reduced dramatically.

Lifting power is set by selecting any of 10 part-load levels.

It is possible to pick up partial loads rapidly and without a problem. The CFR (Compensated Field Reduction) system enables a stack of plates to be separated efficiently and reliably, right down to the last plate, even in the case of very thin plates.

OPERATING COMFORT

The control state of the magnets is indicated on both the crane and the operating console, which continues to function even if the main power supply fails.

Should the power supply fail temporarily, there is no need for concern. SP™ will switch automatically from backup battery to mains supply as soon as the mains power is restored.

Battery life is considerably extended by the use of a temperature-compensated booster and trickle charge system. The battery can be checked automatically by pressing a button.

A master crane PLC can operate the SP™ controller, integrating all magnet functions.

SP™ is small enough to be installed even where space is at a premium.

****** Please contact Crane Care for further information on TRUNINGER magnets or to discuss your particular magnetic handling application needs ******